

Instructions

MRT Engineering E30 Gr.A DTM trailing arm double adjuster kit

Kit includes (pre-assembled parts):

2x Double adjuster outer ends

2x Spherical bearing inner ends



Notes:

-Fits only BMW E30, E36 Compact and Z3 subframe and trailing arms

-Racing part with NO warranty, not for use on public roads

-Manufacturer disclaims all liability for direct, indirect, incidental or consequential damages, including damage or loss of equipment, cost of purchase or replacement of goods, accident or injuries, or claims of the purchaser that result from the use of the part

Double adjusters are hard chrome plated for better corrosion resistance, **grind off the plating** and **disassemble the adjuster and spherical inner joint** before welding:



Adjusters and spherical bearings need to be arranged as in the picture:

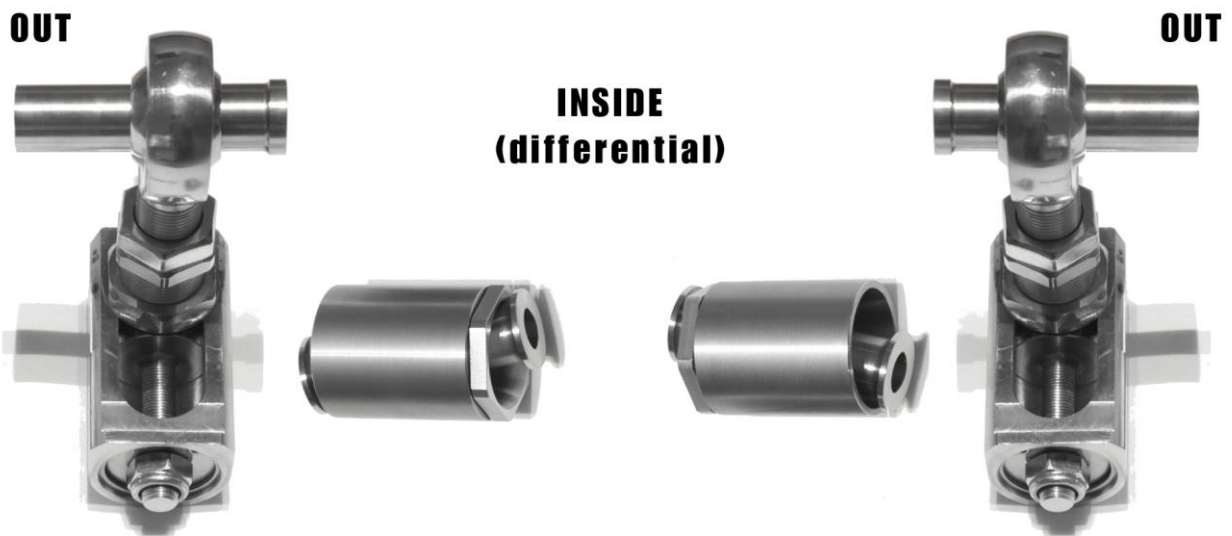

A-brace reinforcement is required when used with floating outer end!

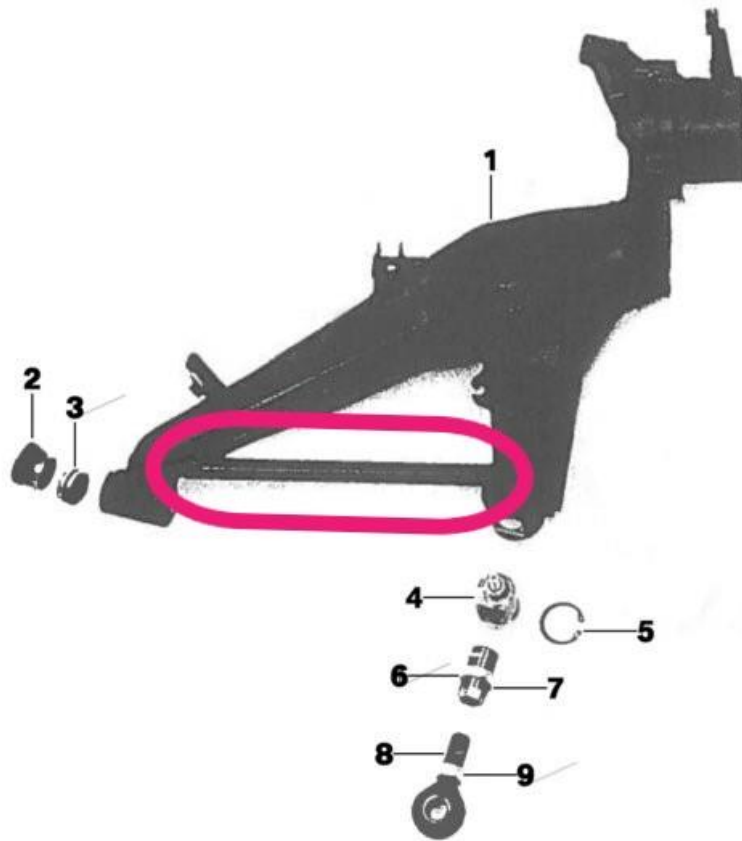

438045

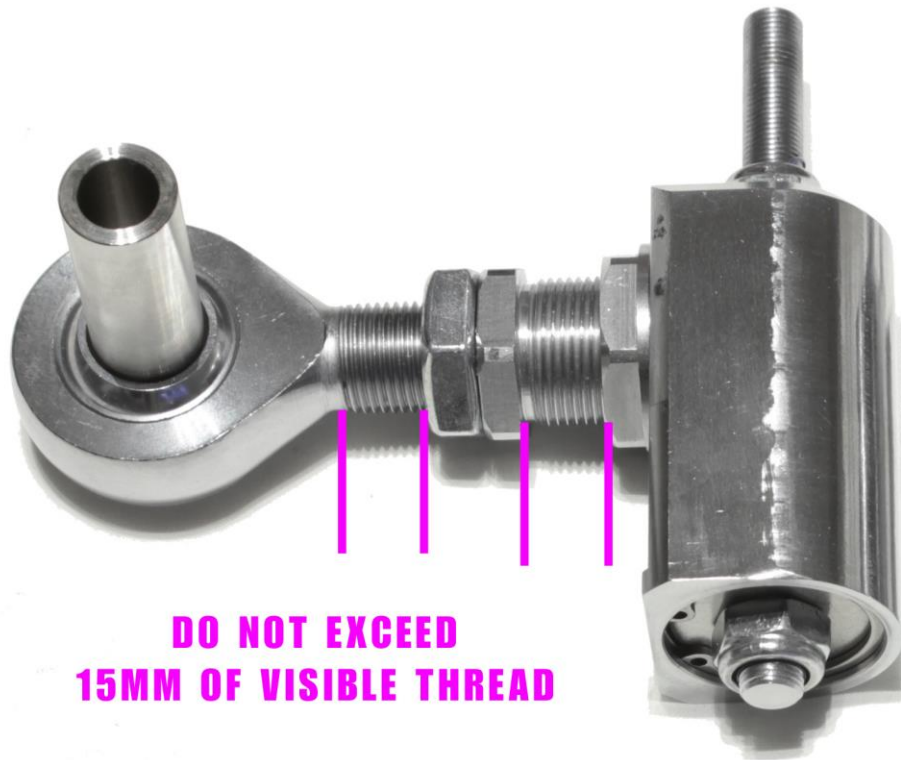

NOTE:

- Remember to check bolt tensions after first 100km/miles
- Check bolt tensions occasionally
- Check adjuster kit condition before and after every trackday
- Regular check, cleaning and maintenance can increase adjuster kit lifetime significantly
- If you have any questions, problems etc, please contact us:
info@mrtengineering.fi